

Next - Gen

G300D

Triaxial Gyroscope with VELOX™



The Next-Gen, SX2, G300D Gyroscope offers the latest advancements in inertial technology. This high speed, three-axis MEMS gyro is equipped with low noise sensors, cutting edge VELOX™ processing and user configurable firmware with the most advanced features available. The G300D comes fully modeled and calibrated over temperature and is the premier MEMS gyroscope for stabilization and precision measurement applications.

0.0017°/s/√Hz
ARW

10 kHz
Output Rate

0.075°/s
Bias Over Temperature

600Hz
Bandwidth

0.6
Cubic Inches

20μs
Message Delay

Low Noise. High Speed.
Inertial Systems and Sensors



G300D Gyroscope

Performance

Range	490°/s
ARW	0.0017°/s/√Hz / 0.072°/√Hz
Bias In-Run	3.5°/h
Bias Over Temperature	0.075°/s
G Sensitivity	< 0.01°/s/g
Scale Factor Error	≤ 0.05%

Environment

Shock (Operational)	1000g's ½ sine 1 msec powered
Vibration (Operational)	8 gRMS (50 Hz to 2 kHz)
Calibrated Temp	-50°C to 85°C
Storage Temp	-55°C to 85°C

Interface

	VELOX™	VELOX™ Plus
Data Interface	RS-422/485	16/24/32 Bit
Data Rate	8 kHz	10 kHz
External Sync	8 kHz	10 kHz
Max Baud Rate	3.0 Mbaud	7.5 Mbaud (user specified)
Max Bandwidth	350 Hz	600 Hz
Digital Message Delay	57 μs	20 μs

Electrical

Input Voltage	+3.8 V to + 5.5 V Max (single sided)
Power Consumption	200 mW Typical / 250 mW Maximum

Mechanical

Mass	19 grams
Size	Metric: 2.54 x 2.54 x 1.52 = 9.81 cm ³ US: 1.0 x 1.0 x 0.6 = 0.6in ³

All performance parameters typical value
Specification subject to change without notice
Rev. 8.08.22

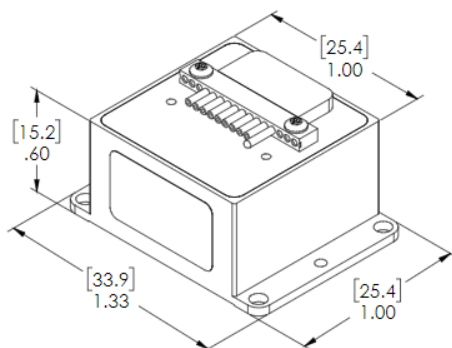

Further Technical
Information Available:

sales@gladiatortechnologies.com

NON ITAR
ECCN 7A994



GLADIATOR
TECHNOLOGIES

Gladiator Technologies
8022 Bracken PI SE
Snoqualmie, WA 98065, USA

425.363.4180
www.gladiatortechnologies.com
sales@gladiatortechnologies.com