

# SI1000 – DATASHEET

Single axis analog accelerometer

SI1000 is a high-end capacitive MEMS accelerometer specially designed for Strong Motion Class B seismic measurements.

Thanks to extremely low noise, low power, wide frequency response, small sized (LCC20) hermetically sealed package, SI1000 guarantees very accurate and stable seismic measurements, requiring neither recalibration nor maintenance during the lifecycle of the system.

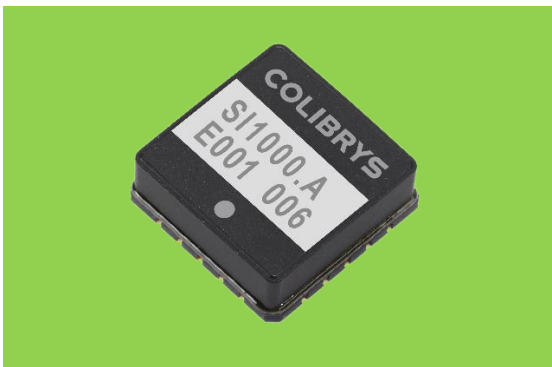

## Functional Block Diagram

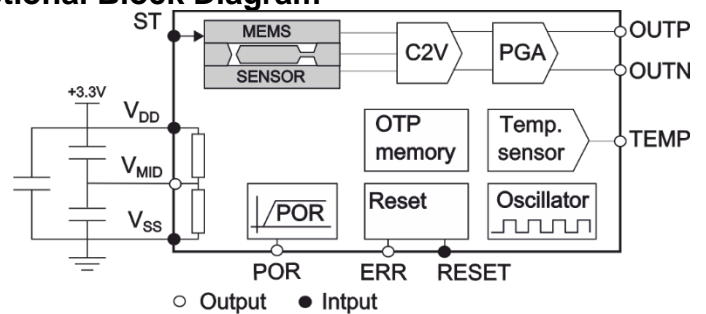

### Key features (typ.)

- **Ranges:** +/-3, 5 g
- **Low Noise:** 0.7  $\mu\text{g}/\sqrt{\text{Hz}}$  (+/-3g)
- **Bandwidth:** 0-550Hz (+/-3g)
- **Non linearity :**  $\pm 0.3\%$  FS
- **Size :** <math>1\text{cm}^2</math>
- **Embedded logic functions:** Self-test, reset

Key Parameter, typical values	SI1003	SI1005	Unit
Full-Scale acceleration	$\pm 3$	$\pm 5$	g
White Noise	0.7	1.2	$\mu\text{g}/\sqrt{\text{Hz}}$
Noise (Integrated over 0.1Hz to 100Hz)	8	13	$\mu\text{g}$
Dynamic range (0.1Hz to 100Hz)	108.5	108.5	dB
Scale Factor Sensitivity	900	540	mV/g
Bandwidth ( $\pm 3\text{dB}$ )	550	700	Hz
Operational temperature	-40 to +85	-40 to +85	$^{\circ}\text{C}$
Operating power consumption	90	90	mW
Size	9 x 9	9 x 9	$\text{mm}^2$

### Featured Applications (non-exhaustive):

#### Seismic

Structural Health Monitoring of critical civil infrastructure (dams, bridges, buildings)  
High density urban monitoring networks  
Safety systems

#### Industrial

Low noise industrial measurements

**SI1003 PARAMETERS**

All values are specified at ambient temperature (20°C) and at 3.3 V supply voltage  $V_{DD}$ , unless otherwise stated. Acceleration values are defined for differential signal (OUTP-OUTN).

Parameter	Comments	Min	Typ.	Max	Unit
<b>Accelerometer</b>					
Full scale		±3			g
White Noise	In band		0.7	0.9	µg/√Hz
Noise	Integrated over 0.1Hz to 100Hz		8		µg
Dynamic range	for 100Hz bandwidth		108.5		dB
Non-Linearity	IEEE Norm , % of full scale		0.3	1	%
Frequency response	+3dB	450	550		Hz
Resonant frequency			1.0		kHz
Quality factor			10		a.u
Startup time	Sensor operational, delay once POR triggered		20		µs
<b>Bias (K0)</b>					
Nominal	Calibration accuracy	-10		10	mg
Temperature coefficient	Measured over [-40°C , 85°C]	-0.3		0.3	mg/°C
<b>Scale factor (K1)</b>					
Nominal	Calibration accuracy	886	900	914	mV/g
Temperature coefficient	Measured over [-40°C , 85°C]		120		ppm/°C
<b>Axis misalignment</b>					
Cross axis coupling				-40	dB
		-10		10	mrad
<b>Self-test</b>					
Frequency		14	19	24	Hz
Duty cycle			50		%
Amplitude			0.25		g
Input threshold voltage		80			% $V_{DD}$
<b>Temperature sensor</b>					
Output voltage @20°C		1.20	1.23	1.26	V
Sensitivity			-4.0		mV/°C
Output current load				10	µA
Output capacitive load				10	pF
<b>Reset</b>					
Input threshold voltage	active low			20	% $V_{DD}$
<b>Power requirements</b>					
Supply voltage ( $V_{DD}$ )		3.2	3.3	3.4	V
Supply current ( $I_{DD}$ )		22	27	32	mA
<b>Accelerometer outputs</b>					
Output voltages	OutP, OutN over full scale	0.14		3.16	V
Differential output	Over full scale		±2.7		V
Resistive load		1000			kΩ
Capacitive load				100	pF

Table 1: SI1003 Specifications

**SI1005 PARAMETERS**

All values are specified at ambient temperature (20°C) and at 3.3 V supply voltage  $V_{DD}$ , unless otherwise stated. Acceleration values are defined for differential signal (OUTP-OUTN).

Parameter	Comments	Min	Typ.	Max	Unit
<b>Accelerometer</b>					
Full scale		±5			g
White Noise	In band		1.2	1.5	$\mu\text{g}/\sqrt{\text{Hz}}$
Noise	Integrated over 0.1Hz to 100Hz		13		$\mu\text{g}$
Dynamic range	for 100Hz bandwidth		108.5		dB
Non-Linearity	IEEE Norm , % of full scale		0.3	1	%
Frequency response	+3dB	600	700		Hz
Resonant frequency			1.3		kHz
Quality factor			10		a.u
Startup time	Sensor operational, delay once POR triggered		20		$\mu\text{s}$
<b>Bias (K0)</b>					
Nominal	Calibration accuracy	-17		17	mg
Temperature coefficient	Measured over [-40°C , 85°C]	-0.5		0.5	$\text{mg}/^\circ\text{C}$
<b>Scale factor (K1)</b>					
Nominal	Calibration accuracy	531	540	549	mV/g
Temperature coefficient	Measured over [-40°C , 85°C]		120		$\text{ppm}/^\circ\text{C}$
<b>Axis misalignment</b>					
Cross axis coupling				-40	dB
		-10		10	mrad
<b>Self-test</b>					
Frequency		14	19	24	Hz
Duty cycle			50		%
Amplitude			0.5		g
Input threshold voltage		80			% $V_{DD}$
<b>Temperature sensor</b>					
Output voltage @20°C		1.20	1.23	1.26	V
Sensitivity			-4.0		$\text{mV}/^\circ\text{C}$
Output current load				10	$\mu\text{A}$
Output capacitive load				10	pF
<b>Reset</b>					
Input threshold voltage	active low			20	% $V_{DD}$
<b>Power requirements</b>					
Supply voltage ( $V_{DD}$ )		3.2	3.3	3.4	V
Supply current ( $I_{DD}$ )		22	27	32	mA
<b>Accelerometer outputs</b>					
Output voltages	OutP, OutN over full scale	0.14		3.16	V
Differential output	Over full scale		±2.7		V
Resistive load		1000			k $\Omega$
Capacitive load				100	pF

Table 2: SI1005 Specifications

## Absolute maximum ratings

Absolute maximum ratings are stresses ratings. Stresses above these ratings can cause permanent damage to the device. Exposure of the device to the absolute maximum ratings for an extended period may degrade the device and affect its reliability.

Parameter	Comments	Min	Typ	Max	Unit
Supply voltage (V <sub>DD</sub> )		-0.3		+3.9	V
Voltage at any PIN		-0.3		V <sub>DD</sub> +0.3	V
Operational temperature		-40		85	°C
Storage temperature		-55		125	°C
Vibration	Random / 20-2'000Hz			20	g
Shock	Single shock / 0.15ms			1'500	g
ESD stress	HBM model	-1		1	kV

Table 3: Absolute maximum ratings

### Typical performances characteristics

**SI1003:** Typical initial performances on multiple sensors at 3.3 VDC supply voltage ( $V_{DD}$ ) and ambient temperature for all graphs, unless otherwise stated (multiple sensors: multiple color line / min-max: red line / typical value: green line).

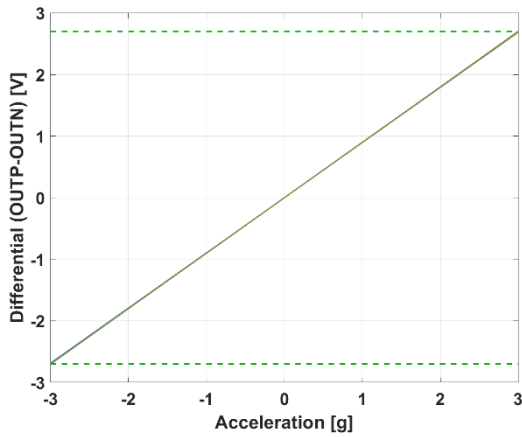

Figure 1: Differential acceleration output (OUTP-OUTN) at full scale

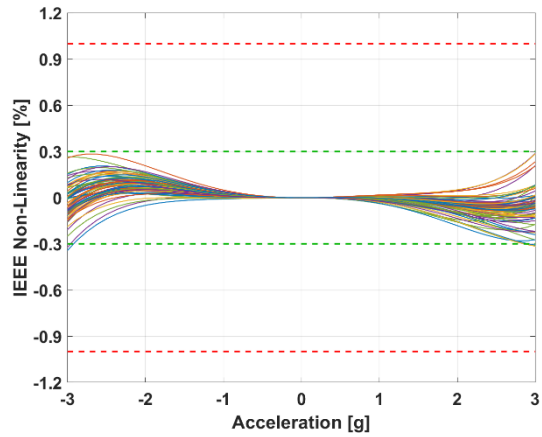

Figure 2: Non-Linearity IEEE

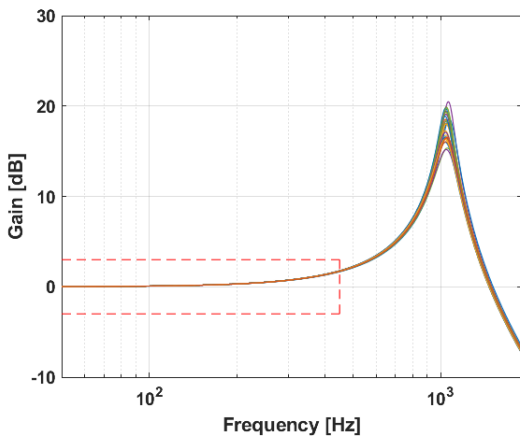

Figure 3: Frequency response

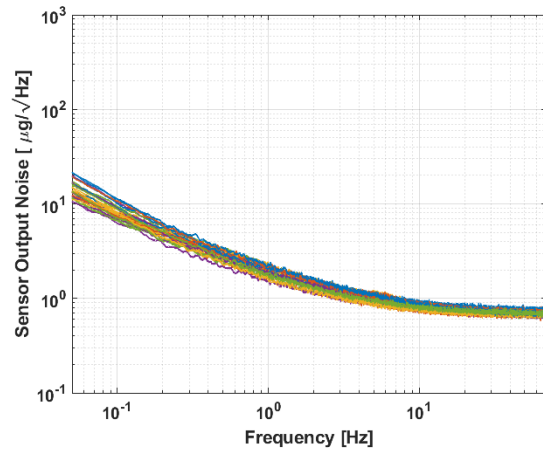

Figure 4: Noise Spectrum

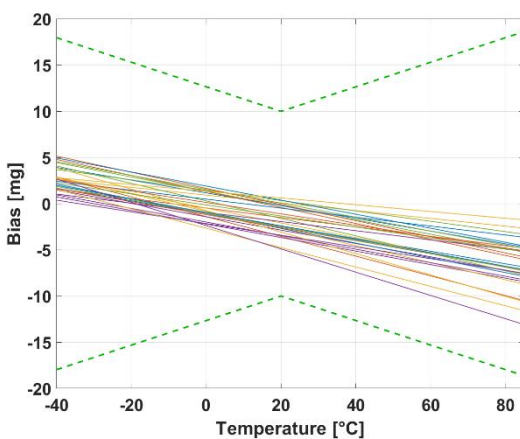

Figure 5: Bias over temperature

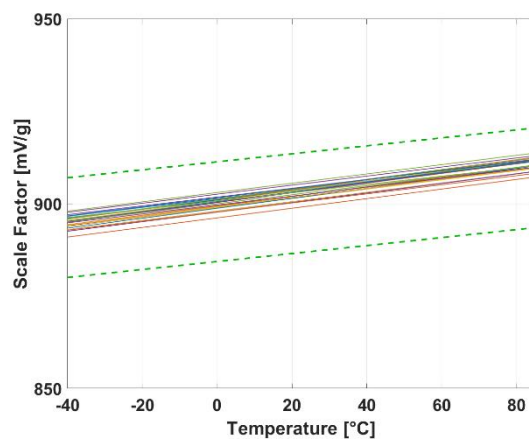

Figure 6: Scale Factor over temperature

**SI1005:** Typical initial performances on multiple sensors at 3.3 VDC supply voltage ( $V_{DD}$ ) and ambient temperature for all graphs, unless otherwise stated (multiple sensors: multiple color line / min-max: red line / typical value: green line).

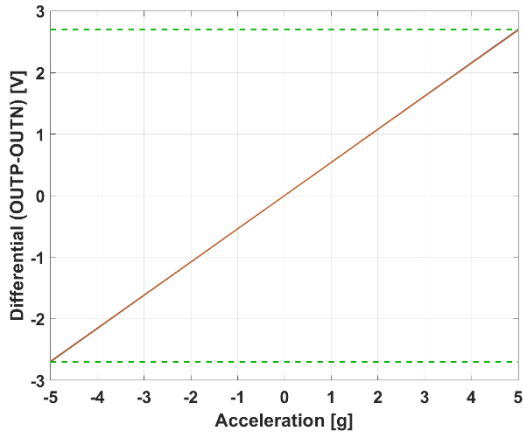

Figure 7: Differential acceleration output (OUTP-OUTN) at full scale

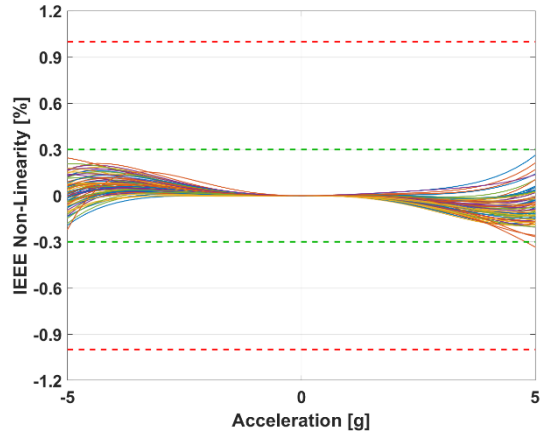

Figure 8: Non-Linearity IEEE

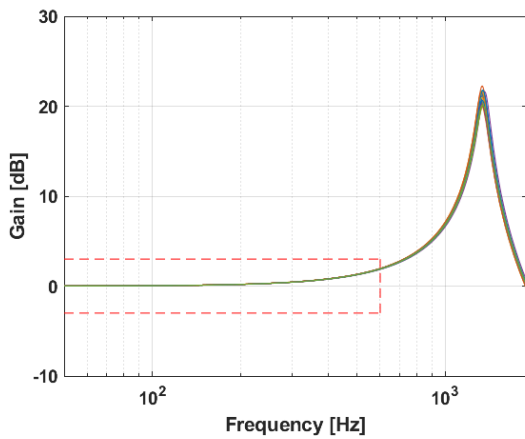

Figure 9: Frequency response

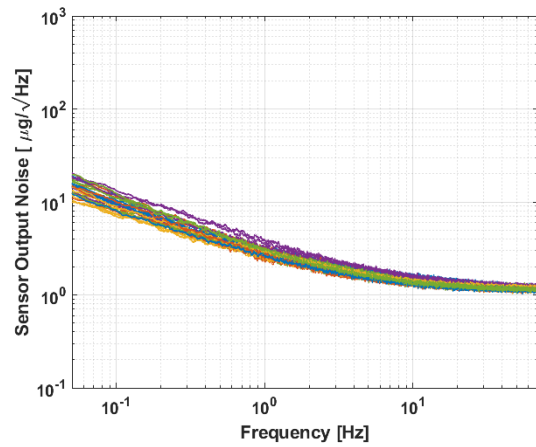

Figure 10: Noise Spectrum

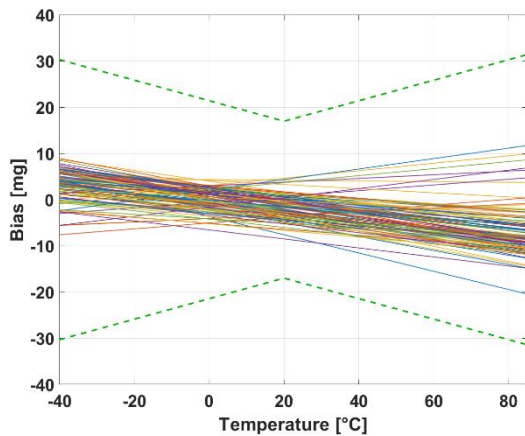

Figure 11: Bias over temperature

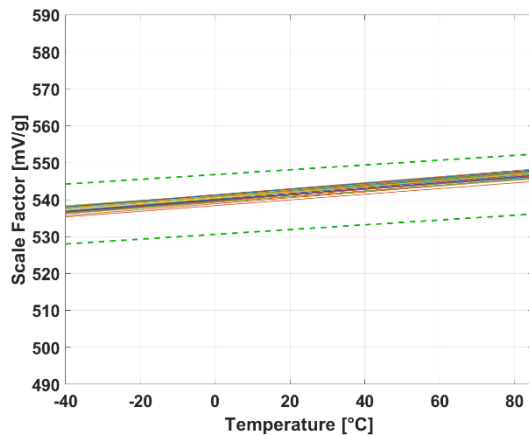

Figure 12: Scale factor over temperature

### Pinout description

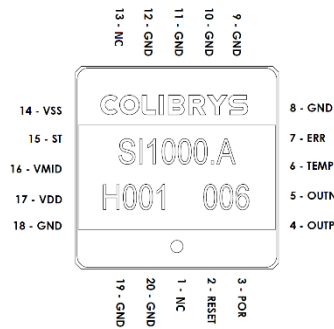

Figure 13: Pinout top view

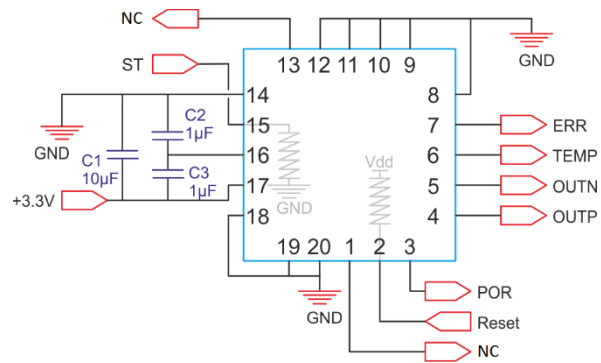

Figure 14: Proximity circuit & internal pull-up/down

The device pin layout is given in Figure 13 and a description of each pin given in Table 4. The capacitors C1 (10 µF), C2 (1 µF) and C3 (1 µF) are shown in Figure 14 and must be placed as close as possible to the SI1000 package and are used as decoupling capacitors and for a proper sensor startup.

Pin Nb.	Pin name	Type	Description
2	RESET	LI, PU	System reset signal, active low
3	POR	LO	Power On Reset, active low
4	OUTP	AO	Differential output positive signal
5	OUTN	AO	Differential output negative signal
6	TEMP	AO	Temperature analogue output
7	ERR	LO	Error signal, active high
14	V <sub>SS</sub> (0 V)	PWR	Connect to ground plane
15	ST	LI, PD	Self-test activation, active high
16	V <sub>MID</sub>	AO	Internal electronic circuit reference voltage. To be used for decoupling capacitors only
17	V <sub>DD</sub> (3.3 V)	PWR	Power supply
1, 13	NC	NC	Do Not Connect
8,9,10,11, 12,18,19,20	GND	GND	Must be connected to ground plane (GND)

*PWR, power / AO, analog output / AI, analog input / NC, Not Connected  
LO, logical output / LI, logical input / PD, internal pull down / PU, internal pull up*

Table 4: SI1000 pinout description

## Electrical Functions description

### Introduction

SI1000 has electrical logic functions embedded such as Power-On-Reset, External reset, Error function and built in Self-test. All those functions are described below. In addition sensor saturation is also described.

### POR (Power-On-Reset) function

The POR block continuously monitors the power supply during startup as well as normal operation. It ensures a proper startup of the sensor and acts as a brownout protection in case of a drop in supply voltage.

During sensor power on, the POR signal stays low until the supply voltage reaches the POR threshold voltage ( $V_{TH}$ ) and begins the startup sequence (see Figure 15). In case of a supply voltage drop, the POR signal will stay low until the supply voltage exceeds  $V_{TH}$  and is followed by a new startup sequence. The ERR signal is high (equal to  $V_{DD}$ ) until the startup sequence is complete.

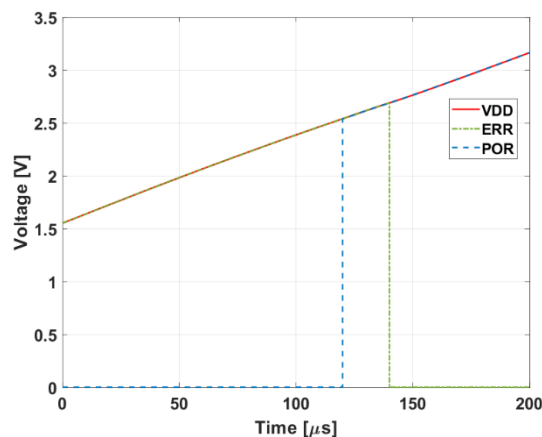

Figure 15: Typical sensor power sequence using recommended circuit

### External Reset

An external reset can be activated by the user through the RESET input pin. During a reset phase, the accelerometer outputs (OUTP & OUTN) are forced to  $V_{DD} / 2$  and the error signal (ERR) is activated (high), see Figure 16.

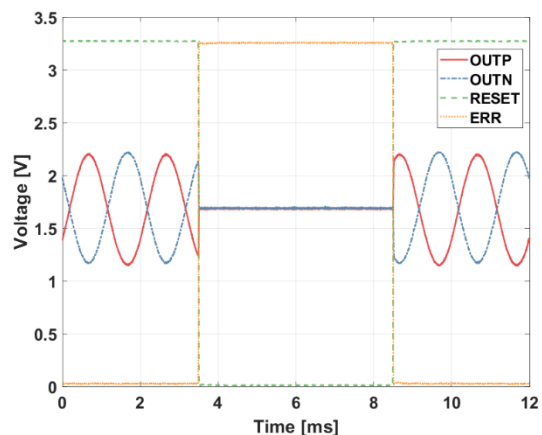

Figure 16: Typical sensor reset sequence with external reset

### Error function

The device continuously monitors the validity of the accelerometer input. An error can be raised in the following cases:

- Out-of-tolerance power supply voltage (POR low), such as during power on
- During external reset phase (user activation of the reset, See Figure 16)



**Built-in Self-Test function**

The built-in Self-Test mode generates a square wave signal on the device outputs (OUTP & OUTN) and can be used for device failure detection (see Figure 17).

When activated, it induces an alternating electrostatic force on the mechanical sensing element and emulates an input acceleration at a defined frequency. This electrostatic force is in addition to any inertial acceleration acting on the sensor during self-test; therefore it is recommended to use the self-test function under quiescent conditions.

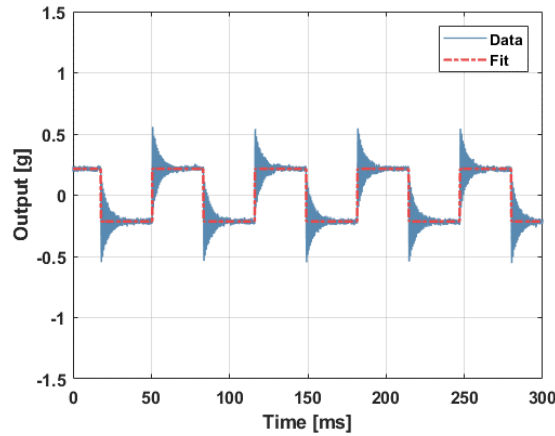

Figure 17: Built-in Self-Test signal on the differential acceleration output ( $f \approx 19\text{Hz}$ ;  $a \approx \pm 0.25\text{g}$ )

**Sensor Saturation**

Upon a high-amplitude acceleration input, the sensor saturates around 1.2 times its full scale acceleration. This behavior is illustrated in the figures below:

- The sensor detects acceleration up to its saturation.
- When saturation ends, the sensor returns to nominal acceleration sensing.

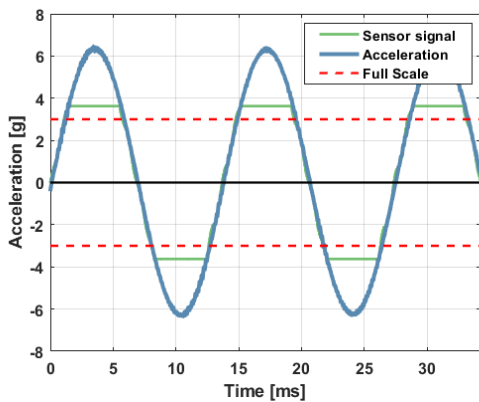

Figure 18: 3g Sensor behavior under 6g sine

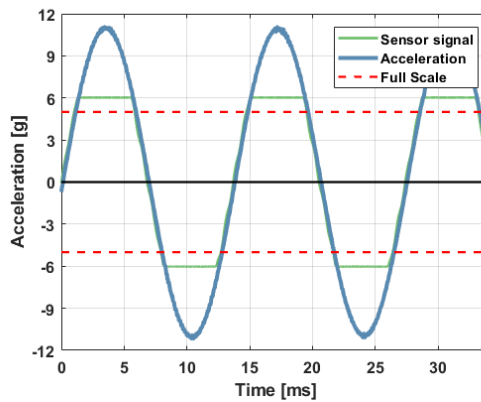

Figure 19: 5g Sensor response to 11g sine

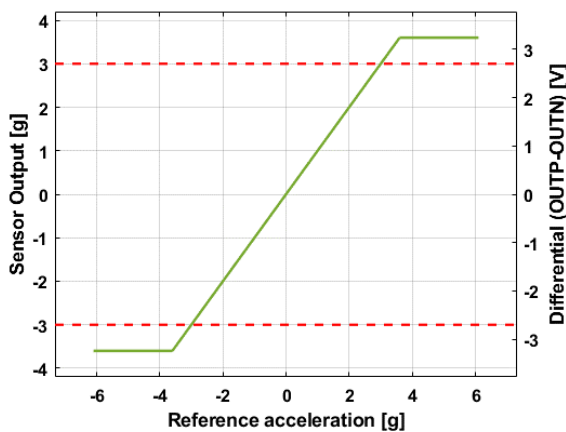

Figure 20: SI1003 versus reference sensor

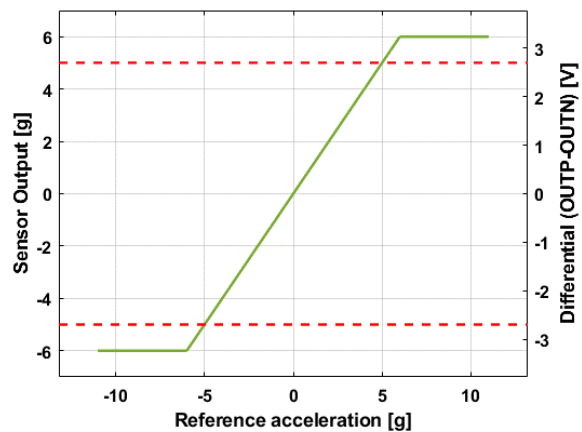

Figure 21: SI1005 versus reference sensor

## Dimensions and package specifications

The outline of the LCC20 ceramic package and the Center of Gravity (CG) is illustrated in the Figure 22.

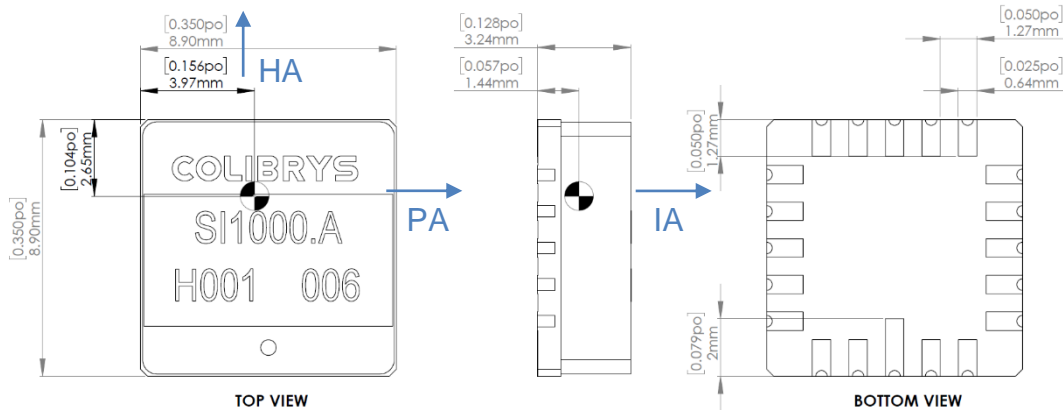

Figure 22: Package mechanical dimension. Units are mm [inch]

Parameter	Comments	Min	Typ	Max	Unit
Lead finishing	Au plating	0.5		1.5	µm
	Ni plating	1.27	4	8.89	µm
	W (tungsten)	10		15	µm
Hermeticity	According to MIL-STD-883-G			5-10-8	atm·cm <sup>3</sup> /s
Weight				1.5	grams
Size	X		8.9	9.2	mm
	Y		8.9	9.2	mm
	Z		3.23	3.5	mm
Packaging	RoHS compliant part. Nonmagnetic, LCC20 pin housing.				
Proximity effect	The sensor is sensitive to external parasitic capacitance. Moving metallic objects with large mass or parasitic effect in close proximity of the accelerometer (mm range) must be avoided to ensure best product performances. A ground plane below the accelerometer is recommended as a shielding.				
Reference plane for axis alignment	LCC must be tightly fixed to the circuit board, using the bottom of the housing as the reference plane for axis alignment. Using the lid as reference plane or for assembly may affect specifications and product reliability (i.e. axis alignment and/or lid soldering integrity)				

Table 5: Package specifications

## Recommended circuit

In order to obtain the best device performance, particular attention must be paid to the proximity analog electronics. A proposed circuit that includes a reference voltage, the sensor decoupling capacitors and output buffers is described in Figure 23.

Optimal acceleration measurements are obtained using the differential output ( $OUTP_B - OUTN_B$ ). If a single-ended acceleration signal is required, it must be generated from the differential acceleration output in order to remove the common mode noise.

### Block Diagram & Schematic

The main blocks that require particular attention are the power supply management, the accelerometer sensor electronic and the output buffer.

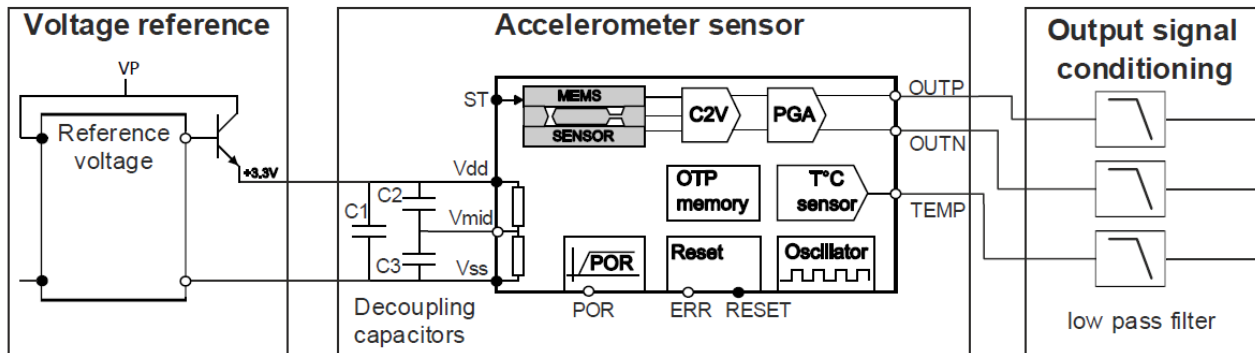

Figure 23: Recommended Block diagram

### Voltage reference

The accelerometer output is ratiometric to the voltage reference and its performance will directly impact the accelerometer performances. Therefore, a low-noise, high-stability and low-thermal drift voltage reference is recommended. For optimal performances the acceleration in the sensitive axis should be expressed as:

$$A_s = \frac{OUT_P - OUT_N}{VDD} * 3.3$$

The electronic circuit within the accelerometer is based on a switched-capacitor architecture. High-frequency noise or spikes on the voltage reference will affect the outputs and induce a signal within the device bandwidth. Key performance of voltage reference should be:

- In-band Output Noise < 0.3µV/√Hz
- High frequency output < 1µV/√Hz up to 10MHz
- Output temperature coefficient < 10ppm/°C

### Accelerometer sensor

The sensor block is composed of the SI1000 accelerometer and the 3 decoupling capacitors: C1 [10µF], C2 [1µF] and C3 [1µF]. These capacitors are mandatory for the proper operation and full performance of the accelerometer. We recommend placing them as close as possible to the SI1000 package on the printed circuit board.

### Output signal conditioning

The output signal must be correctly filtered and buffered before data acquisition. We recommend using an ultra-low offset, drift and bias current operational amplifier that matches the SI1000 output impedance and a second order low pass filter (LPF) to prevent aliasing of the high frequency noise signal. A typical second order filter with a 6 kHz cut off frequency will attenuate the noise at 340 kHz and 1 MHz by 70dB.

An additional antialiasing low pass filter matching the sampling frequency has to be implemented.

### SMD recommendation

A recommended land pattern for LCC20 is shown in Figure 24. It should be tested and qualified in the manufacturing process. The land pattern and pad sizes have a pitch of 1.27mm and the pin 1 is longer to ensure the right orientation of the product during mounting. After assembly, the orientation can be controlled from the top with an extra point printed on the lid which corresponds to pin 1.

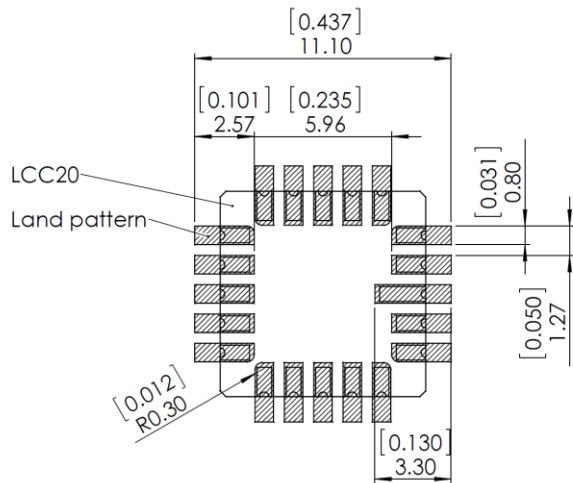

Figure 24 : LCC20 land pattern recommendation (units are mm/[inch])

The SI1000 is suitable for Sn/Pb and Pb-Free soldering and ROHS compliant. Typical temperature profiles recommended by the solder manufacturer can be used with a maximum ramp-up of 3°C/second and a maximum ramp-down of 6°C/second: The exact profile depends on the used solder paste.

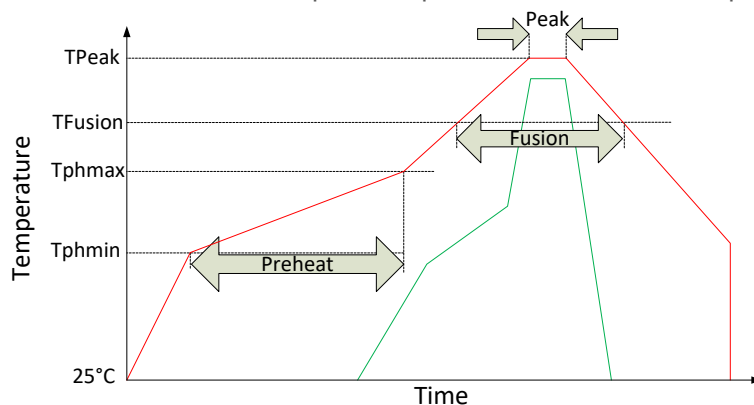

Figure 25: Soldering Temperature Profile

Phase	Sn/Pb		Pb-Free	
	Duration [sec]	Temperature [°C]	Duration [sec]	Temperature [°C]
Peak	10-30	235-240	20-40	245-250
Fusion	60-150	183	60-150	217
Preheat	60-120	Min : 100 Max : 150	60-180	Min : 150 Max : 200

Table 6: Soldering temperatures & times

The cleaning process of electronic boards sometimes involves ultrasounds. This is strongly prohibited on our sensors. Ultrasonic cleaning will have a negative impact on silicon elements which generally causes damages.



**Note: Ultrasonic cleaning is forbidden in order to avoid damage of the MEMS accelerometer**

## Handling and packaging precautions

### Handling

The SI1000 is packaged in a hermetic ceramic housing to protect the sensor from the ambient environment. However, poor handling of the product can induce damage to the hermetic seal (Glass frit) or to the ceramic package made of brittle material (alumina). It can also induce internal damage to the MEMS accelerometer that may not be visible and cause electrical failure or reliability issues. Handle the component with caution: shocks, such as dropping the accelerometer on hard surface, may damage the product.



**It is strongly recommended to use vacuum pens to manipulate the accelerometers**

The component is susceptible to damage due to electrostatic discharge (ESD). Therefore, suitable precautions shall be employed during all phases of manufacturing, testing, packaging, shipment and handling. Accelerometer will be supplied in antistatic bag with ESD warning label and they should be left in this packaging until use. The following guidelines are recommended:

- Always manipulate the devices in an ESD-controlled environment
- Always store the devices in a shielded environment that protects against ESD damage (at minimum an ESD-safe tray and an antistatic bag)
- Always wear a wrist strap when handling the devices and use ESD-safe gloves



**This product can be damaged by electrostatic discharge (ESD). Handle with appropriate precautions.**

### Packaging

Our devices are placed in trays for shipment and SMD process. They are packed in sealed ESD-inner bag. We strongly advice to maintain our device in its original OEM sealed ESD inner-bag to guarantee storage condition before soldering them.

### Product identification markings

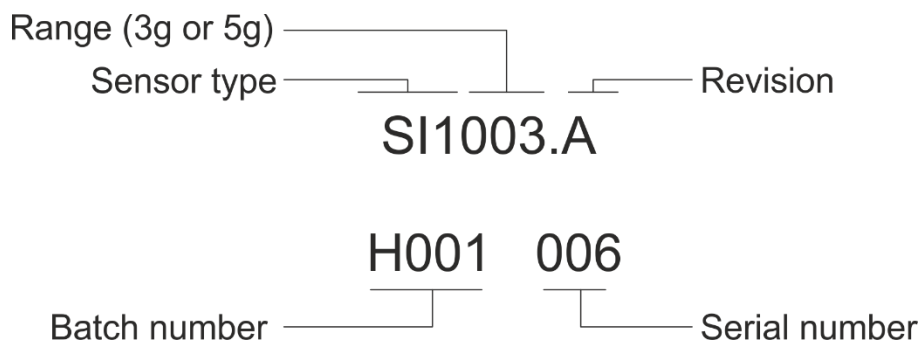

### Ordering Information

Description	Product	Measurement range
Single analog axis MEMS accelerometer, 	SI1003.A	±3g
	SI1005.A	±5g

## Glossary of parameters of the Data Sheet

### Accelerometer model

$$\frac{OUT_P - OUT_N}{VDD} * 3.3 = K_1(K_0 + A_s + K_2 \cdot A_s^2 + K_3 \cdot A_s^3 + K_p \cdot A_p + K_h \cdot A_h + K_{sp} \cdot A_s A_p + K_{sh} \cdot A_s A_h + E)$$

$A_s$ ,  $A_p$ ,  $A_h$  are the accelerations for each axes of the sensor with:

Input Axis (IA): Sensitive axis

Pendulous Axis (PA): Aligned with the proof mass beam and perpendicular to the input axis

Hinge Axis (HA): Perpendicular to the input and pendulous axes. Direction of the dot.

$K_1$  is accelerometer scale factor [V/g]

$K_0$  is bias [g]

$K_2$  is second order non-linearity [g/g<sup>2</sup>]

$K_3$  is third order non-linearity [g/g<sup>3</sup>]

$K_p$  is pendulous cross-axis [rad]

$K_h$  is output cross-axis [rad]

$K_{sp}$ ,  $K_{io}$  are cross-coupling coefficients [rad/g]

$E$  is the residual noise [g]

### g [m/s<sup>2</sup>]

Unit of acceleration, equal to standard value of the earth gravity (Accelerometer specifications and data supplied by Safran Colibrys SA use 9.80665 m/s<sup>2</sup>).

### Dynamic range [dB]

Ratio of rms largest sine to rms self-noise – Root of PSD via Welch method.

$$Dynamic\ range\ [dB] = 20 \log \left[ \frac{Range[g] / \sqrt{2}}{Integrated\ Noise\ 0.1Hz\ to\ 100Hz\ [g]} \right]$$

Acquisition performed at 200sps using an antialiasing filter with  $f_{Corner}$  at  $0.8 * f_{Nyquist}$  and with stop band at least 120dB below the pass band.

### Noise [ $\mu$ g/ $\sqrt{Hz}$ ]

Undesired perturbations in the accelerometer output signal, which are generally uncorrelated with desired or anticipated input accelerations.

### Bias [mg]

The accelerometer output at zero g.

### Scale factor [mV/g]

The ratio of the change in output (in volts) to a unit change of the input (in units of acceleration); thus given in mV/g.

### Temperature sensitivity

Sensitivity of a given performance characteristic (typically scale factor, bias, or axis misalignment) to operating temperature, specified generally at 20°C. Expressed as the change of the characteristic per degree of temperature change; a signed quantity, typically in ppm/°C for scale factor and mg/°C for bias. This figure is useful for predicting maximum scale factor error with temperature, as a variable when modelling is not accomplished.

### Non-linearity, IEEE [% FS]

Absolute maximum error versus full-scale acceleration:

$$NL_{IEEE\ max} \equiv \left| \frac{V - K_1(K_0 + A_s)}{K_1 A_{FS}} \right|_{max} = \left| \frac{K_2 A_s^2 + K_3 A_s^3 + \dots}{A_{FS}} \right|_{max}$$

### Frequency response [Hz]

Frequency range from DC to the specified value where the variation in the frequency response amplitude is less than  $\pm 3$  dB

## Quality

Safran Colibrys is ISO 9001:2015, ISO 14001:2015 and OHSAS 18001:2007 certified



Safran Colibrys complies with the European Community Regulation on chemicals and their safe use (EC 1907/2006) REACH.



SI1000 products comply with the EU-RoHS directive 2011/65/EC (Restrictions on hazardous substances) regulations



Recycling : please use appropriate recycling process for electrical and electronic components (DEEE)



SI1000 products are compliant with the Swiss LSPro : 930.11 dedicated to the security of products

Note:

- *SI1000 accelerometers are available for sales to professionals only*
- *Les accéléromètres SI1000 ne sont disponibles à la vente que pour des clients professionnels*
- *Die Produkte der Serie SI1000 sind nur im Vertrieb für kommerzielle Kunden verfügbar*
- *Gli accelerometri SI1000 sono disponibili alla vendita soltanto per clienti professionisti*

Safran Colibrys complies with due diligence requirements of Section 1502, Conflict Minerals Survey, of the US Dodd-Frank Wall Street Reform and Consumer Protection Act and follows latest standard EICC/GeSI templates for Conflict Minerals declaration



## Disclaimer

Safran Colibrys reserves the right to make changes to products without any further notice.

Performance may vary from the specifications provided in Safran Colibrys' datasheet due to different applications and integration. Operating performance must be validated for each customer application by customer's technical experts. The performance at system level remains the customer's responsibility.

The degolding process applied to the products is excluded from Safran Colibrys recommendations. And if applied, cancels any products warranty and liability.

USE OF THE PRODUCT IN ENVIRONMENTS EXCEEDING THE ENVIRONMENTAL SPECIFICATIONS SET FORTH IN THE DATASHEET WILL VOID ANY WARRANTY. SAFRAN COLIBRYS HEREBY EXPRESSLY DISCLAIMS ALL LIABILITY RELATED TO USE OF THE PRODUCT IN ENVIRONMENTS EXCEEDING THE ENVIRONMENTAL SPECIFICATIONS SET FORTH IN THE DATASHEET.